

Energolux

Техническая инструкция

СПЛИТ-СИСТЕМА LAUSANNE on/off, R410a

 Designed in
Switzerland

www.energolux.com



СОДЕРЖАНИЕ

Спецификация	3
Холодильный контур.....	4
Схема подключения.....	7
Диагностика системы	9

1. Спецификация

1.1 Внешний вид. Серия Lausanne



SAS07L1-A		SAU07L1-A	
SAS09L1-A		SAU09L1-A	
SAS12L1-A		SAU12L1-A	
SAS18L1-A		SAU18L1-A	
SAS24L1-A		SAU24L1-A	
SAS30L1-A		SAU30L1-A	
SAS36L1-A		SAU36L1-A	



1.2 Габаритные размеры

Внутренние блоки

Модель		SAS07L1-A	SAS09L1-A	SAS12L1-A	SAS18L1-A	SAS24L1-A	SAS30(36)L1-A
Ш	мм	700	700	800	850	970	1100
В	мм	285	285	300	300	315	330
Г	мм	188	188	197	198	235	235

Наружные блоки

Модель		SAU07L1-A	SAU09L1-A	SAU12L1-A	SAU18L1-A	SAU24L1-A	SAU30L1-A	SAU36L1-A
Ш	мм	710	710	710	840	835	835	900
В	мм	420	495	495	545	685	685	700
Г	мм	255	240	240	290	305	305	350

Технические характеристики

Модель		SAS07L1-A	SAS09L1-A	SAS12L1-A	SAS18L1-A	SAS24L1-A	SAS30L1-A	SAS36L1-A
Производительность, кВт	Охлаждение	2,1	2,7	3,55	5,3	7,0	7,9	10,4
	Обогрев	2,2	2,8	3,65	5,45	7,2	7,6	10,2
Потребляемая мощность, кВт	Охлаждение	0,65	0,84	1,11	1,66	2,33	2,6	3,5
	Обогрев	0,61	0,78	1,01	1,51	2,11	2,28	3,19
Энергоэффективность, кВт/кВт	Охлаждение	EER / Класс	3,21 / A	3,21 / A	3,21 / A	3,21 / A	3,01 / B	3,01 / B
	Обогрев	COP / Класс	3,61 / A	3,61 / A	3,61 / A	3,61 / A	3,41 / B	3,21 / B
Рабочий ток, А	Охлаждение	2,82	3,66	4,8	7,2	10,1	11,4	15,3
	Обогрев	2,65	3,37	4,39	6,56	9,75	10,3	14,15
Электропитание		1 фаза, 230 В, 50 Гц						
Сторона подключения		Внутренний блок						
Максимальная длина фреонпровода, м		15	15	15	25	25	25	25
Максимальный перепад высот, м		5	5	5	7	10	10	10
Диаметр жидкостной трубы, мм (дюймы)		6,35 (1/4)	6,35 (1/4)	6,35 (1/4)	6,35 (1/4)	6,35 (1/4)	6,35 (3/8)	6,35 (1/4)
Диаметр газовой трубы, мм (дюймы)		9,52 (3/8)	9,52 (3/8)	9,52 (3/8)	12,7 (1/2)	15,88 (5/8)	15,88 (5/8)	15,88 (5/8)
Внутренний блок		SAS07L1-A	SAS09L1-A	SAS12L1-A	SAS18L1-A	SAS24L1-A	SAS30L1-A	SAS36L1-A
Расход воздуха (макс./выс./сред./низк.), м³/ч		480/420/370/330	520/450/400/350	650/560/500/440	980/850/750/660	1200/1050/930/830	1200/1100/980/870	1200/1100/980/870
Осушение, л/ч		0,8	1,0	1,3	1,8	2,2	2,6	3
Уровень звукового давления, дБ(А)		33/29/27/22	33/30/27/22	33/29/27/23	38/35/32/29	40/37/34/30	43/39/36/34	45/41/39/37
Диаметр дренажной трубы, мм		16	16	16	16	16	16	16
Размеры (В x Ш x Г), мм	Без упаковки	285×700×188	285×700×188	300×800×197	300×850×198	315×970×235	330×1100×235	330×1100×235
	В упаковке	355×770×272	355×770×272	370×870×282	355×885×255	385×1047×317	400×1180×317	400×1180×317
Вес, кг	Без упаковки	8	8	10	10,5	15	18	23
	В упаковке	9,65	10,15	11,8	12,4	17,3	21	26
Наружный блок		SAU07L1-A	SAU09L1-A	SAU12L1-A	SAU18L1-A	SAU24L1-A	SAU30L1-A	SAU36L1-A
Расход воздуха, м³/ч		1040	1430	1430	2340	2600	2600	2600
Уровень звукового давления, дБ(А)		48	50	52	54	55	58	58
Гарантированный диапазон рабочих температур наружного воздуха, °С	Охлаждение	+10 ~ +43 (-25 ~ +24 для моделей, доработанных низкотемпературным комплектом)						
	Обогрев	-7 ~ +24						
Заводская заправка хладагента R410a (до 5 м), г		500	640	660	1150	1500	2550	2100
Дополнительная заправка хладагента, г/м		20	20	20	30	30	30	30
Размеры (В x Ш x Г), мм	Без упаковки	420×710×255	495×710×240	495×710×240	545×840×290	685×835×305	685×835×305	700×900×350
	В упаковке	478×770×338	570×780×345	570×780×345	620×920×400	725×945×435	760×935×415	770×1020×430
Вес, кг	Без упаковки	21,5	25	25	38	44	50	70
	В упаковке	24	27,65	27,9	41,7	48,2	54	76

2. Холодильный контур

Только охлаждение

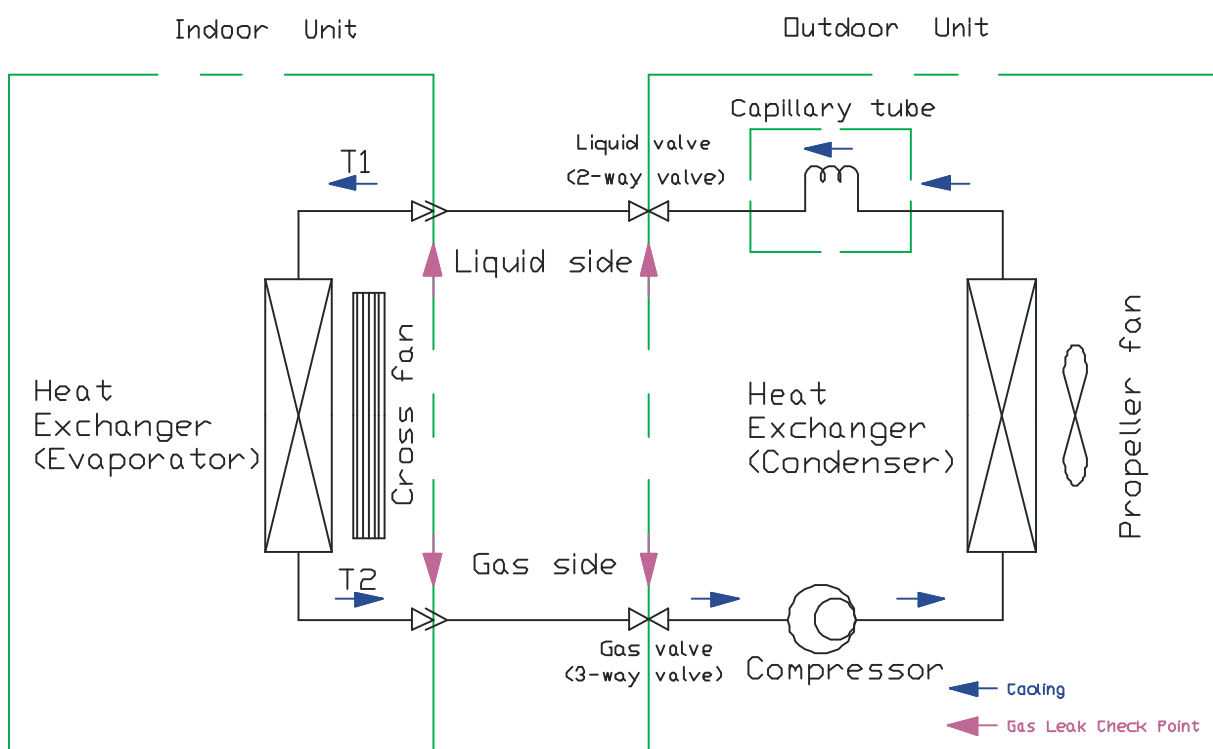

Холодильный цикл

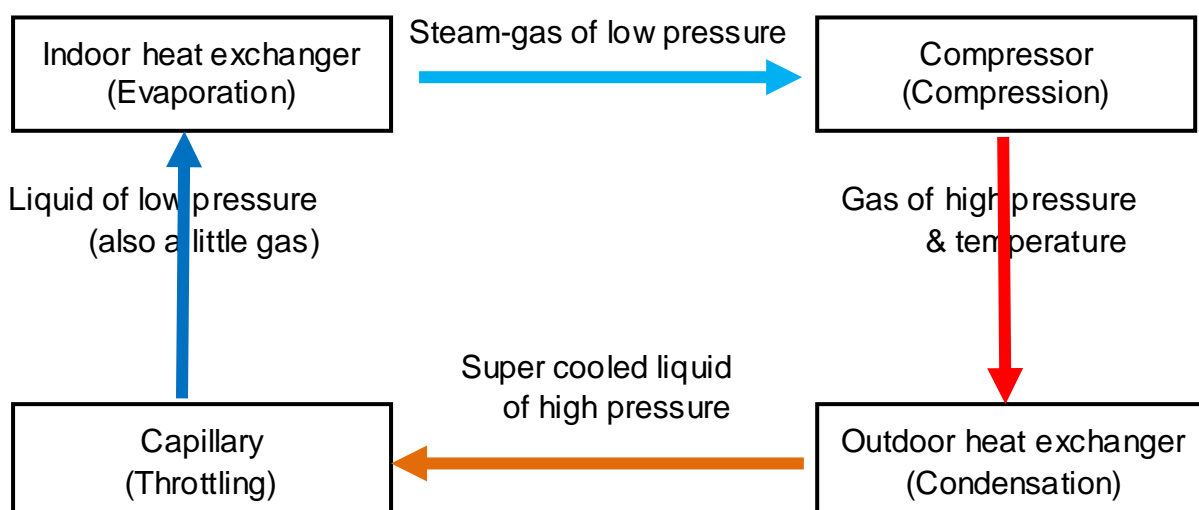

2.2 Охлаждение & Обогрев

Работа системы в режиме охлаждения

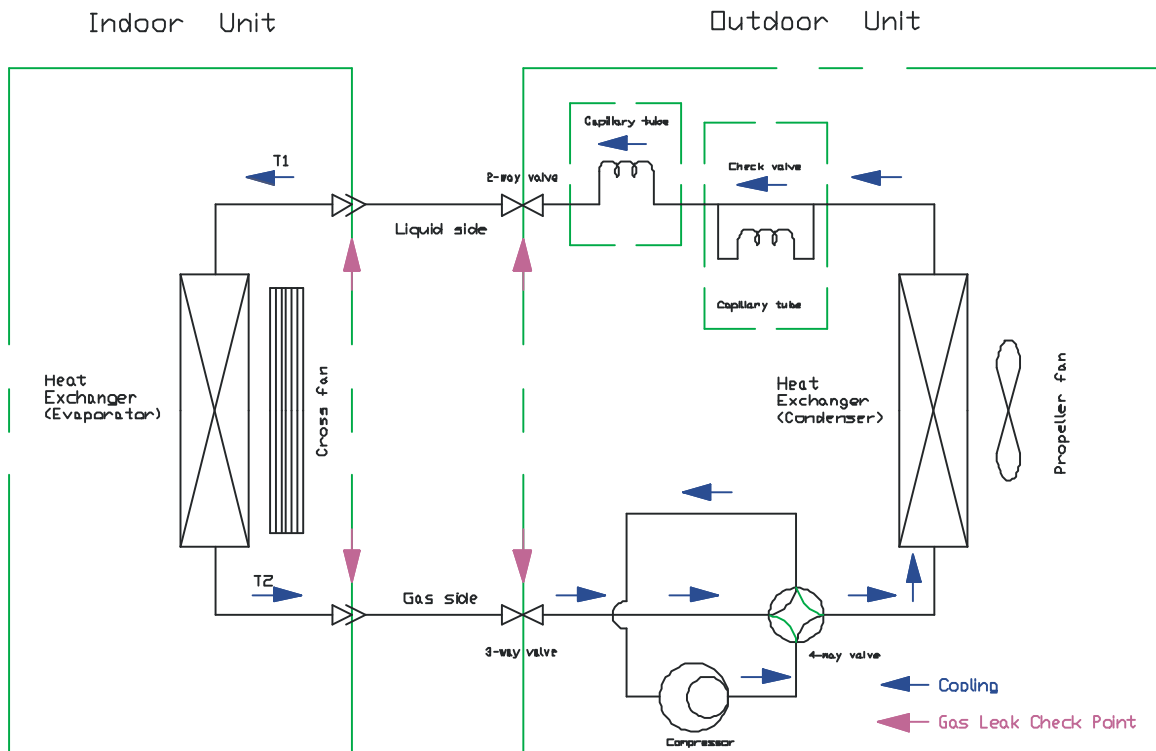

Холодильный цикл в режиме охлаждения

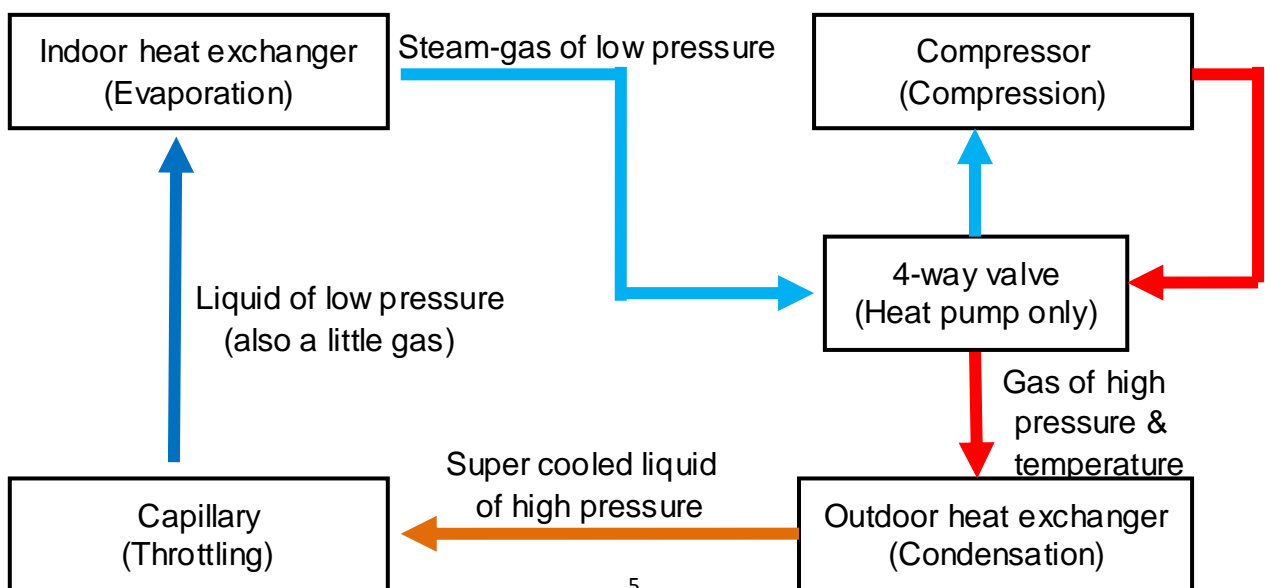

Работа системы в режиме обогрева

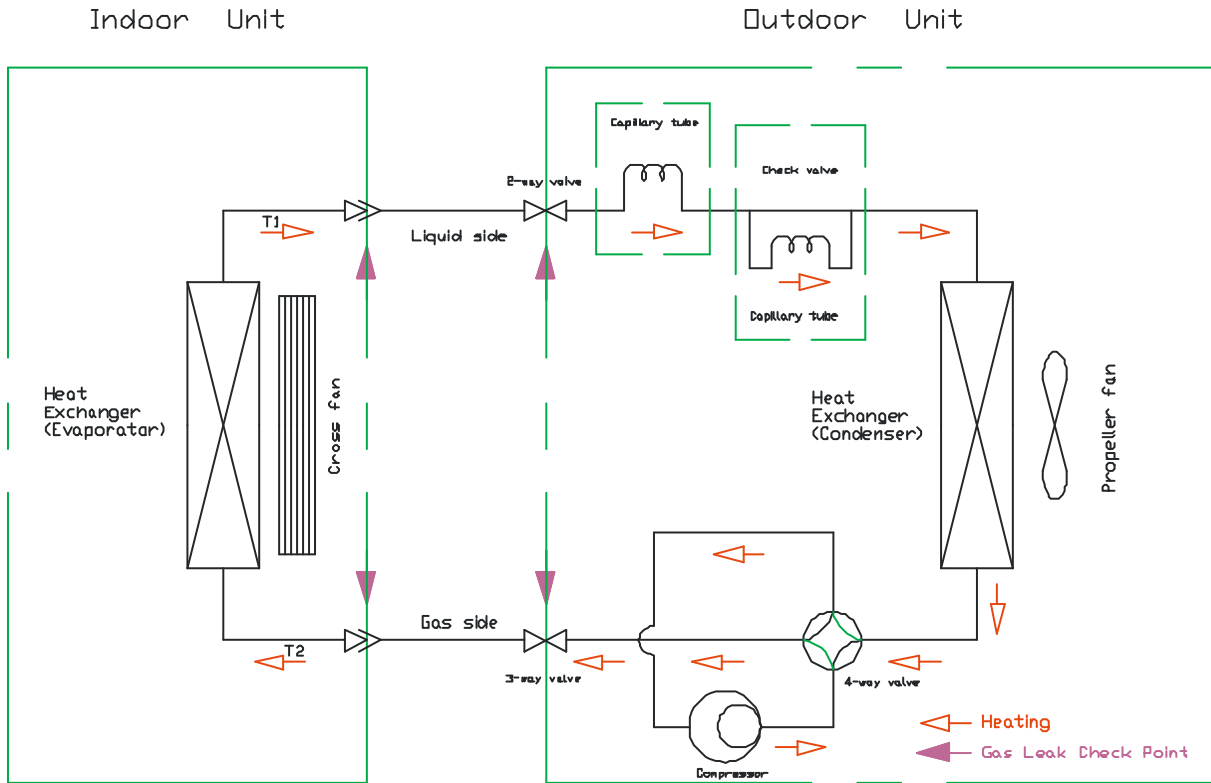

Холодильный цикл в режиме обогрева

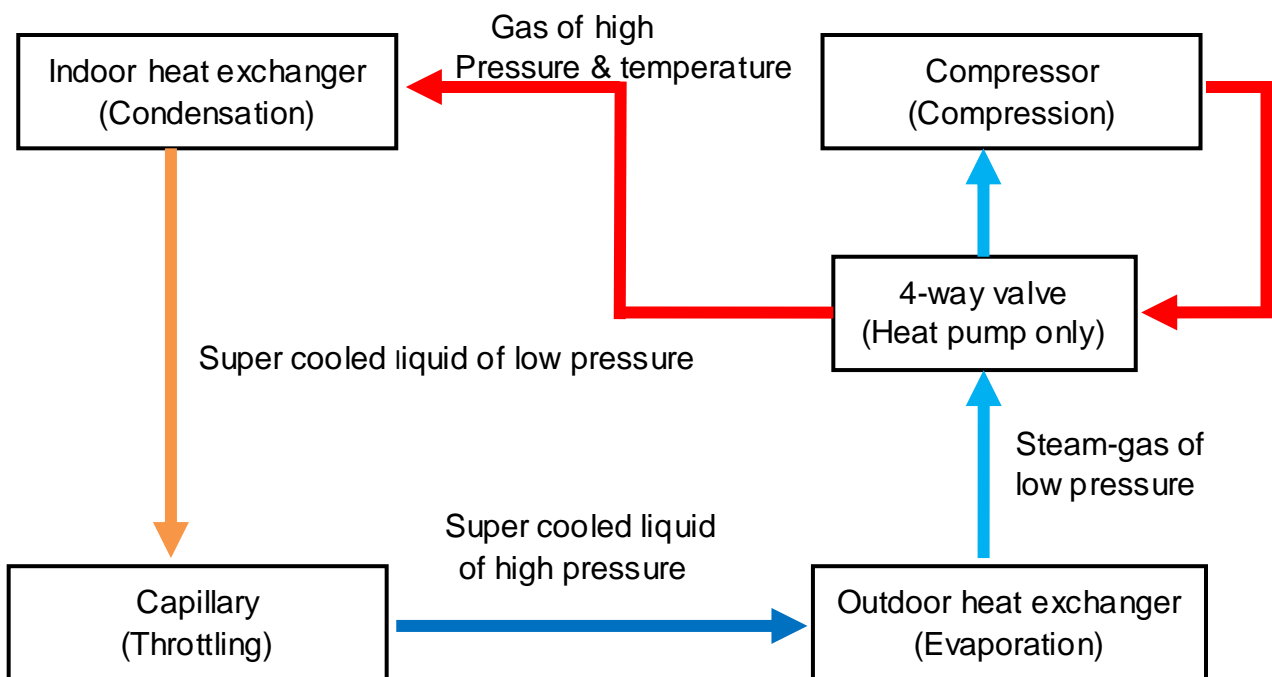

3. Схема подключения

для моделей SAS07/09/12/18L1-A

Внутренний блок



Схема подключения

для моделей SAS24/30/36L1-A

Внутренний блок

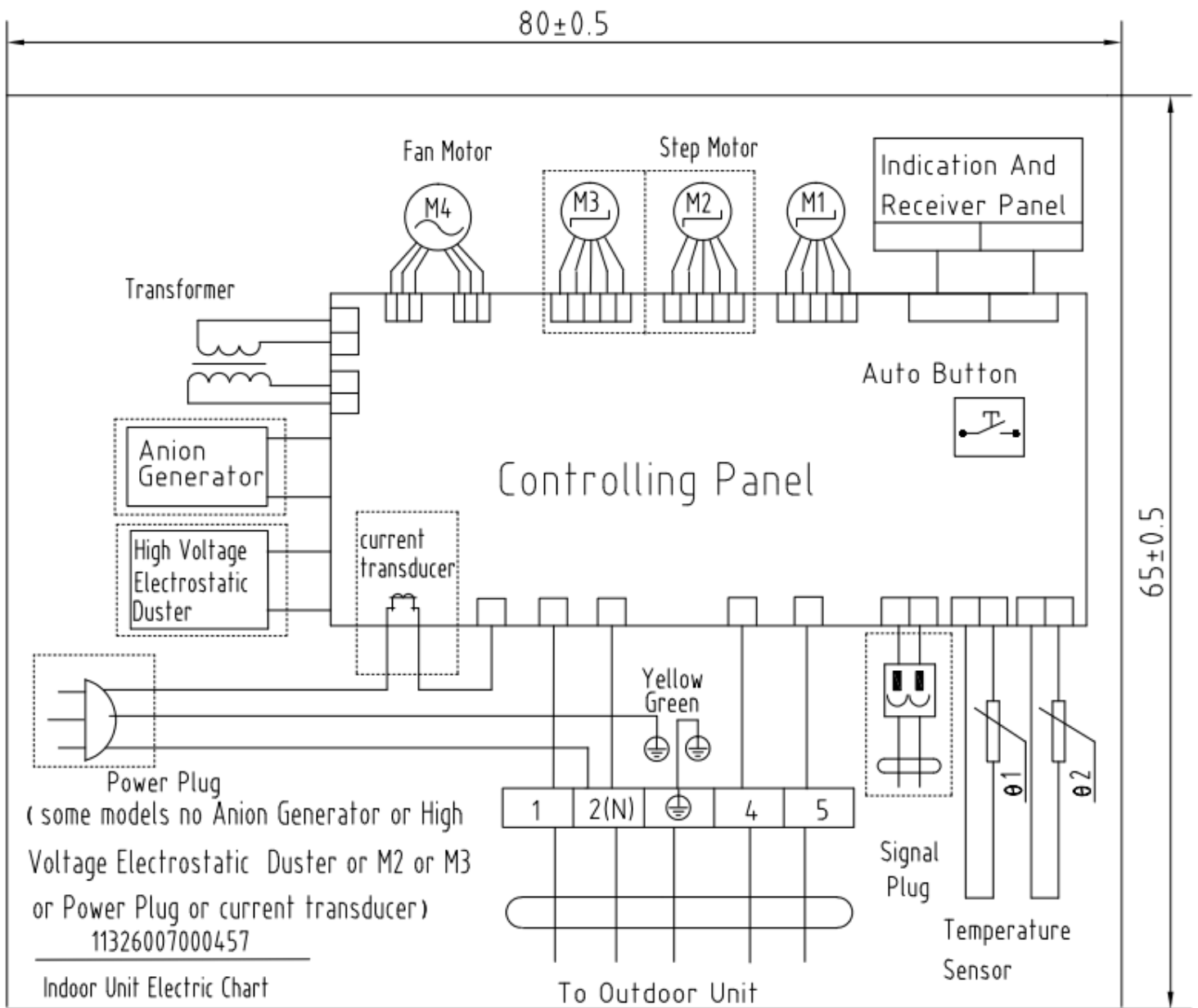
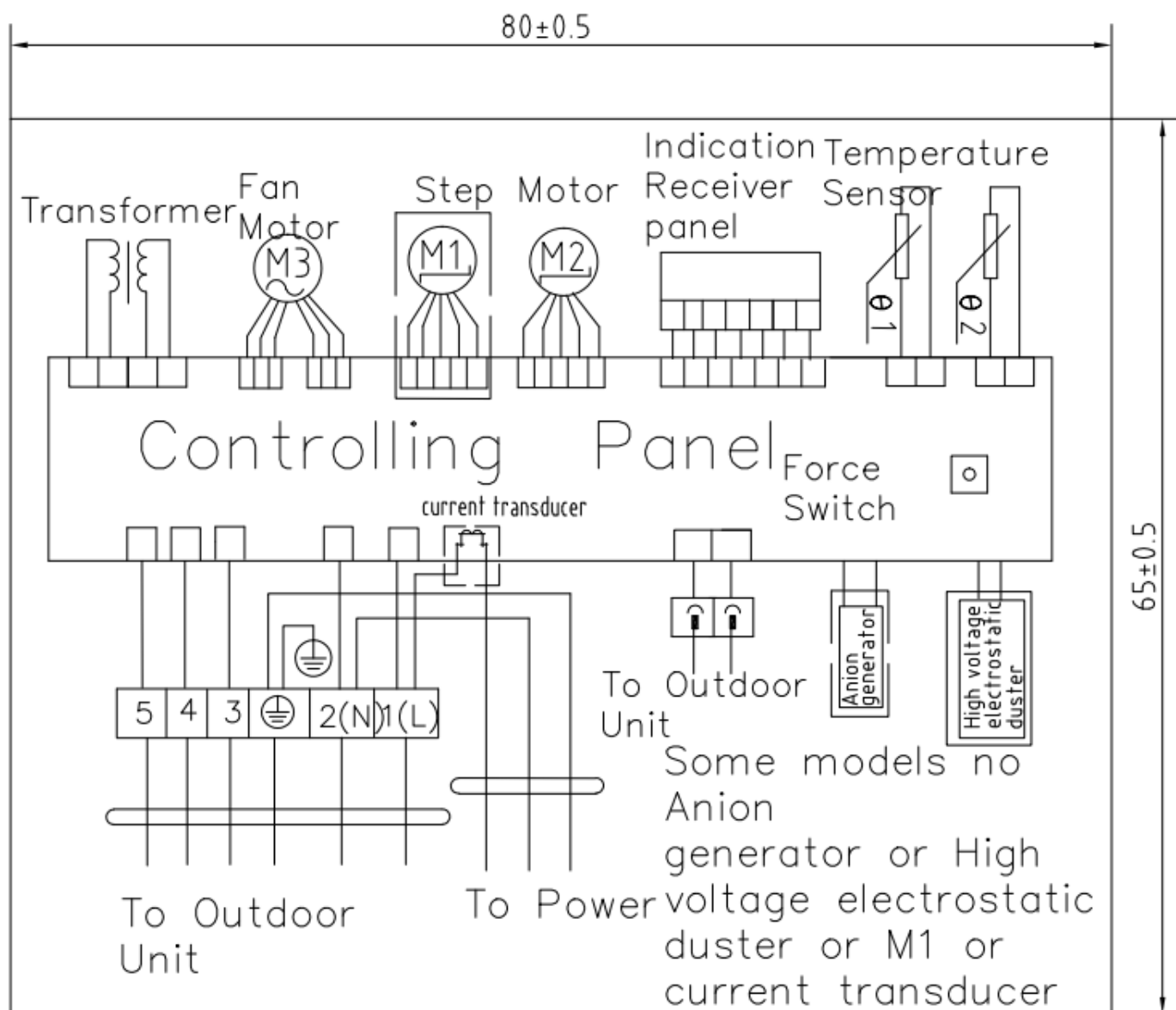

Наружный блок SAU07/09/12/18L1-A

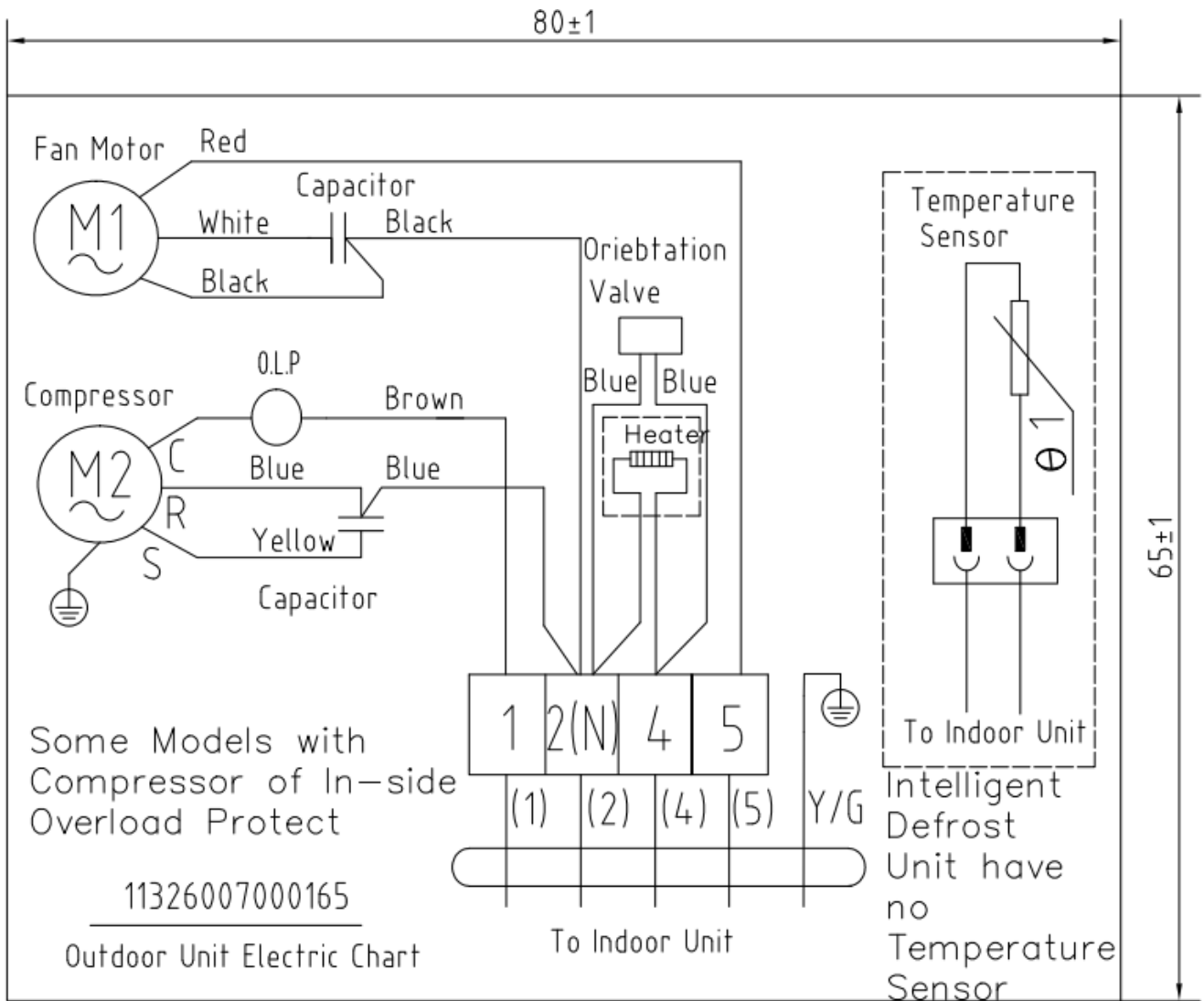

Наружный блок SAU24/30/36L1-A

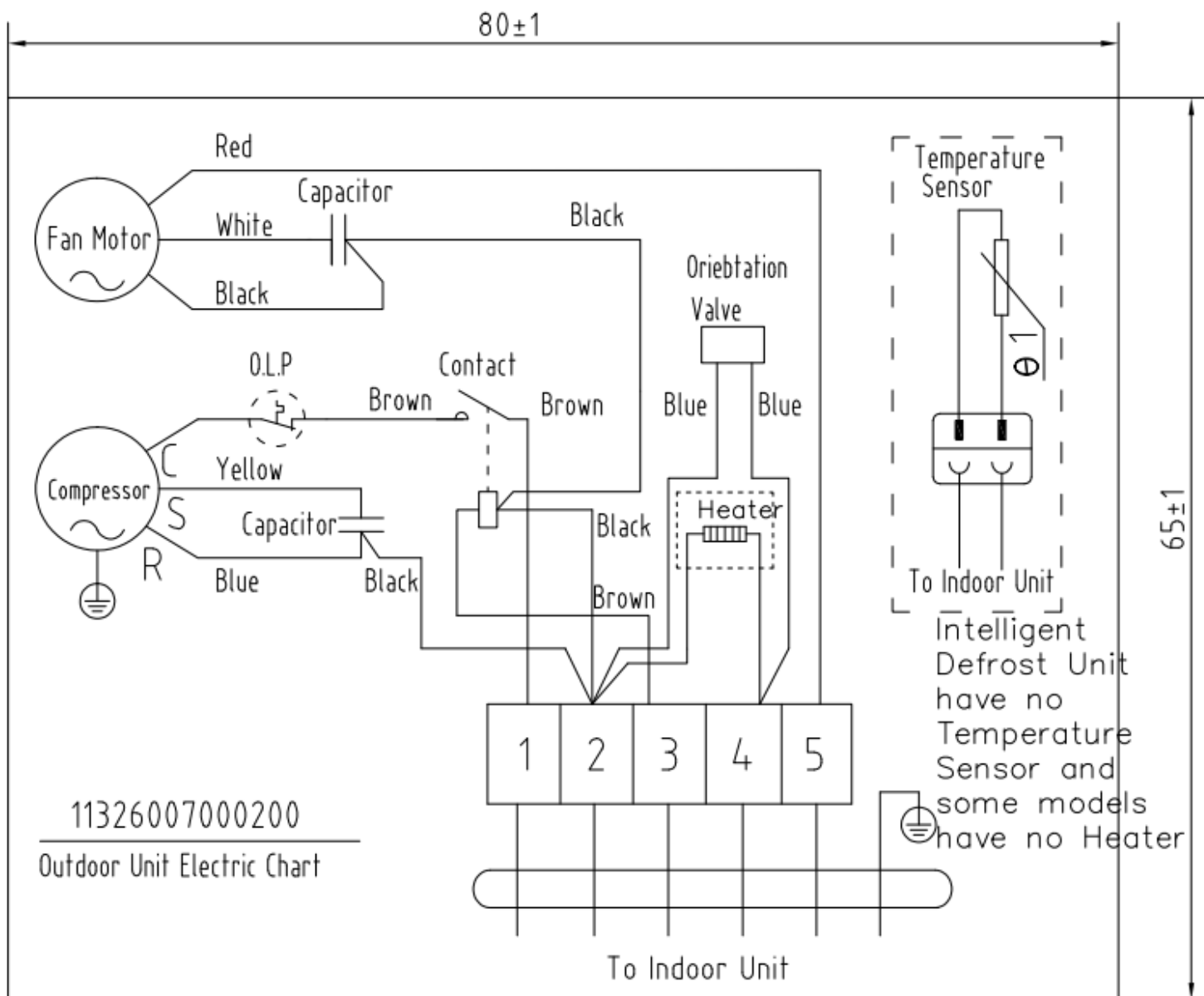

СЕРИЯ	Модель					Рабочий ток		
		Тип питания	Силовой кабель	Межблочный кабель	Питание	Автомат защиты	холод	тепло
						А	А	А
Сплит-системы ON-OFF								
LAUSANNE	SAS07L1-A	230/1	3 x 1,5 мм2	5 x 1,5 мм2	внутр	16	2,82	2,65
	SAS09L1-A	230/1	3 x 1,5 мм2	5 x 1,5 мм2	внутр	16	3,66	3,37
	SAS12L1-A	230/1	3 x 1,5 мм2	5 x 1,5 мм2	внутр	16	4,8	4,39
	SAS18L1-A	230/1	3 x 2,5 мм2	5 x 1,5 мм2	внутр	20	7,2	6,56
	SAS24L1-A	230/1	3 x 2,5 мм2	8 x 2,5 мм2	внутр	25	10,1	9,75
	SAS30L1-A	230/1	3 x 2,5 мм2	8 x 2,5 мм2	наруж	32	11,85	11,04
BASEL	SAS07B1-A	230/1	3 x 1,5 мм2	5 x 1,5 мм2	внутр	16	2,82	2,65
	SAS09B1-A	230/1	3 x 1,5 мм2	5 x 1,5 мм2	внутр	16	3,66	3,37
	SAS12B1-A	230/1	3 x 1,5 мм2	5 x 1,5 мм2	внутр	16	4,8	4,39
	SAS18B1-A	230/1	3 x 2,5 мм2	5 x 1,5 мм2	внутр	20	7,2	6,56
	SAS24B1-A	230/1	3 x 2,5 мм2	8 x 2,5 мм2	внутр	25	10,1	9,75
	SAS30B1-A	230/1	3 x 2,5 мм2	8 x 2,5 мм2	наруж	32	11,85	11,04

5. Диагностика неисправностей

5.1 Коды ошибок

No.	Error Code	Problem
1	E1	Room temperature sensor fault
2	E2	Outdoor coil temperature sensor fault
3	E3	Indoor coil temperature sensor fault
4	E4	indoor fan motor or DC motor feedback fault

5.2 Руководство для моделей SAS07/09/12/18. Алгоритм. Проблемы и их устранение.

1. The Foremost Inspecting Items

(1)The input voltage must be within +10% tolerance of the rated Voltage. If it is not the case, the air-conditioner will probably not work normally.

(2)Check the connecting cord between indoor unit and outdoor unit to see if it is properly connected. The connecting must be done according to the wiring diagram, please also notice that even different models may have the connecting cord of the same specification.

Please check if the marks at the connecting terminal and the marks on the cord can match, otherwise, the air-conditioner will not work normally.

(3)If the following phenomena are found, the problem is not from the air-conditioner itself.

NO.	Problems	Causes
1	The motor is heard operating but the air-conditioner dose not work when the indoor unit is powered on	Since the air-conditioner is powered on, it will come to working condition as long as you press the ON/OFF button of the remote control and the Signal is well received.
2	The compressor stops running but the indoor fan motor keeps working when it is at cooling mode with the indoor temperature higher than set temperature.	If you turn off the air-conditioner and restart it immediately, it will return to normal in 3 minutes, after that, the air-conditioner will automatically adjust the indoor fan speed to what you set.
3	The compressor works discontinuously at dehumidifying mode.	The air-conditioner will automatically control the working of the compressor according to the inside temperature
4	The air-conditioner does not work while the LED display is on.	The TIMER is set with the air-conditioner; it will be in hold on condition. If the TIMER setting is cancelled, the air-conditioner will return to normal working condition
5	The compressor works discontinuously at cooling and dehumidifying mode, and the indoor fan motor slows down.	The compressor stops internally or the fan motor slows down to prevent the indoor heat exchanger from being frozen.

2. No Power Display

(1) Items

- a) Check if the input voltage is correct?
- b) Check if the AC power supply connecting is correct?
- c) Check if the output voltage of the manostat L7805 (IC2) is correct?

(2) Trouble shooting procedure

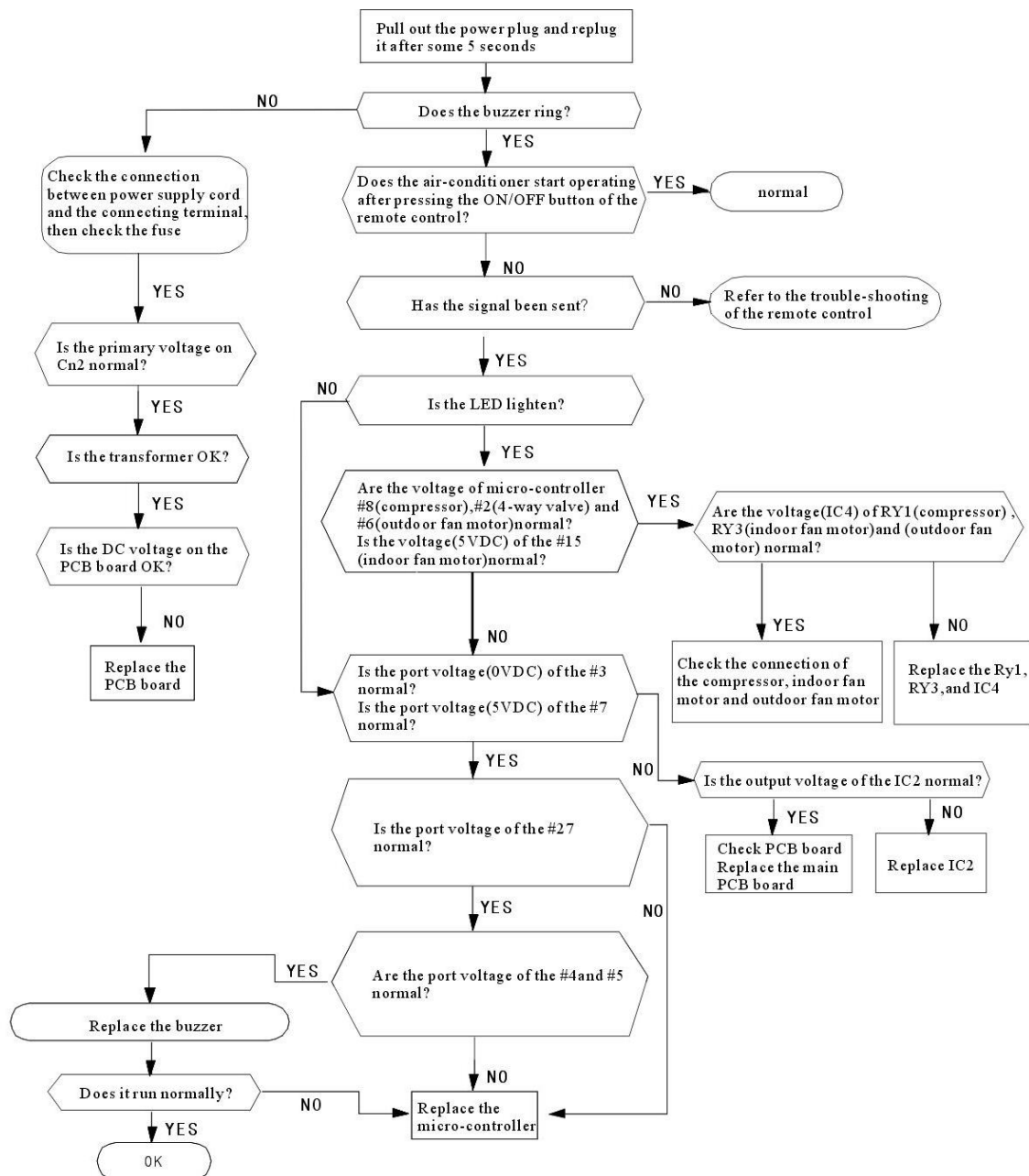

3. The Indoor Fan Motor Does Not Work

(1)Items

- a) Check if the indoor fan motor is connected correctly to the connector (CN8)?
- b) Check if the AC input voltage is correct?
- c) Check if the IC of indoor fan motor is connected correctly to the connector (CN2)?

(CN2)?

- d) Check if the capacity of indoor fan motor is connected correctly to the connector (CN8)?

(2)Trouble shooting procedure

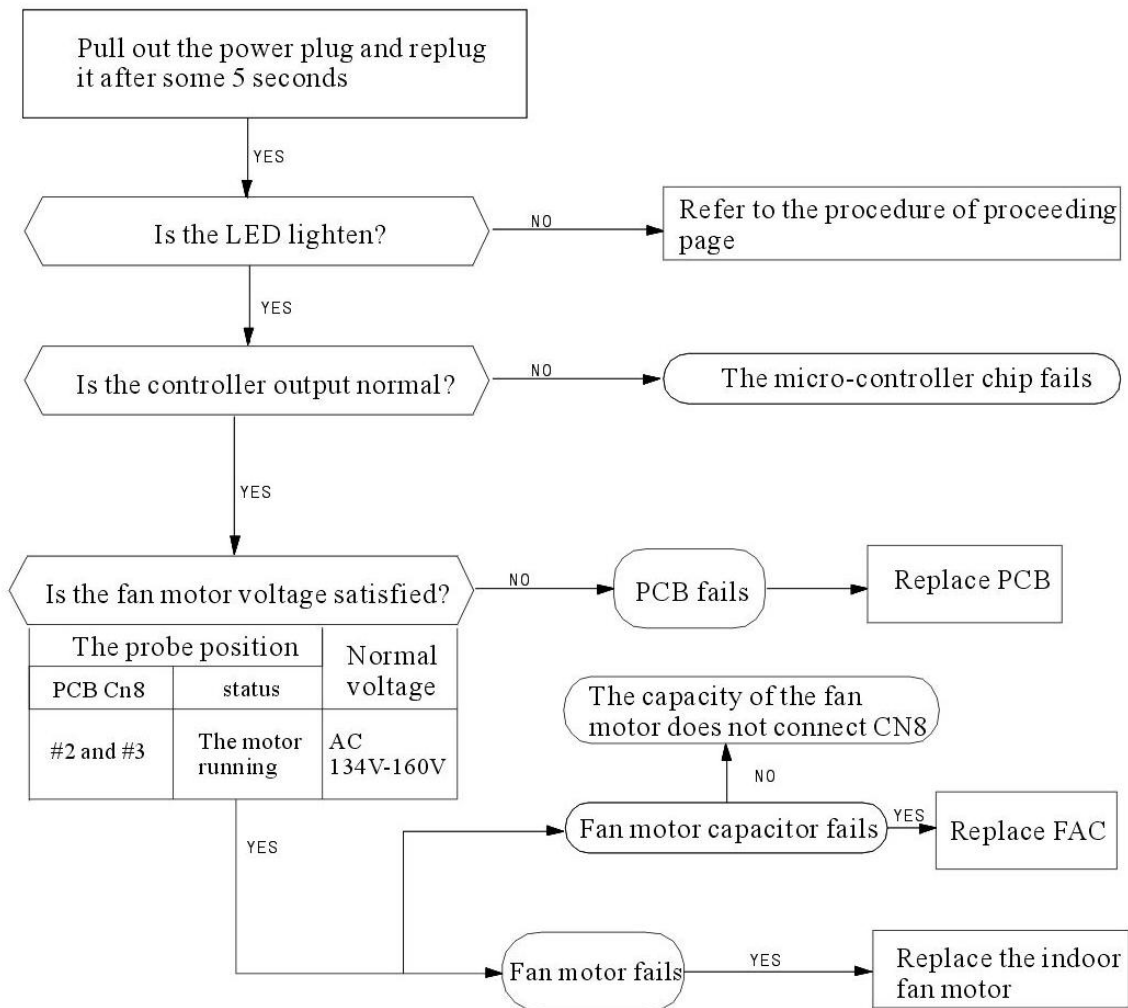

4. The Outdoor Unit Does Not Work

(1) Items

- a) Check if the input voltage is correct?
- b) Check if the wire connection of the outdoor connecting terminal is correct?

(2) Trouble shooting procedure

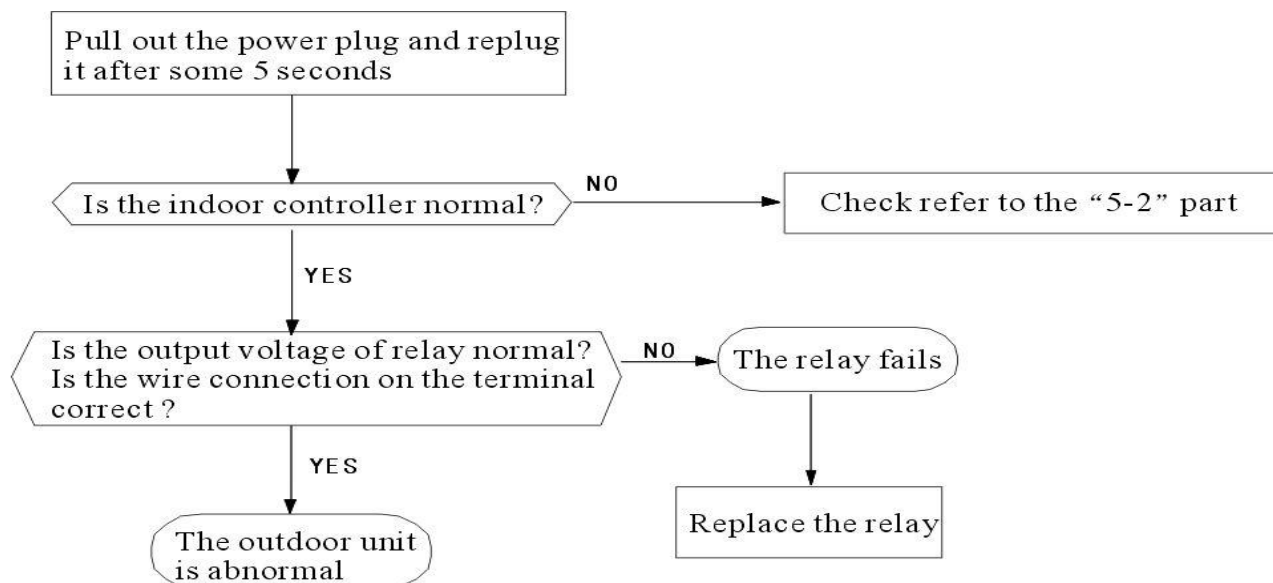

5. The Step Motor Does Not Work

(1)Items

a) Check if the input voltage is correct?

b) Check if the step motor controlling the up-down movement firmly connected to Cn2?

(2)Trouble shooting procedure

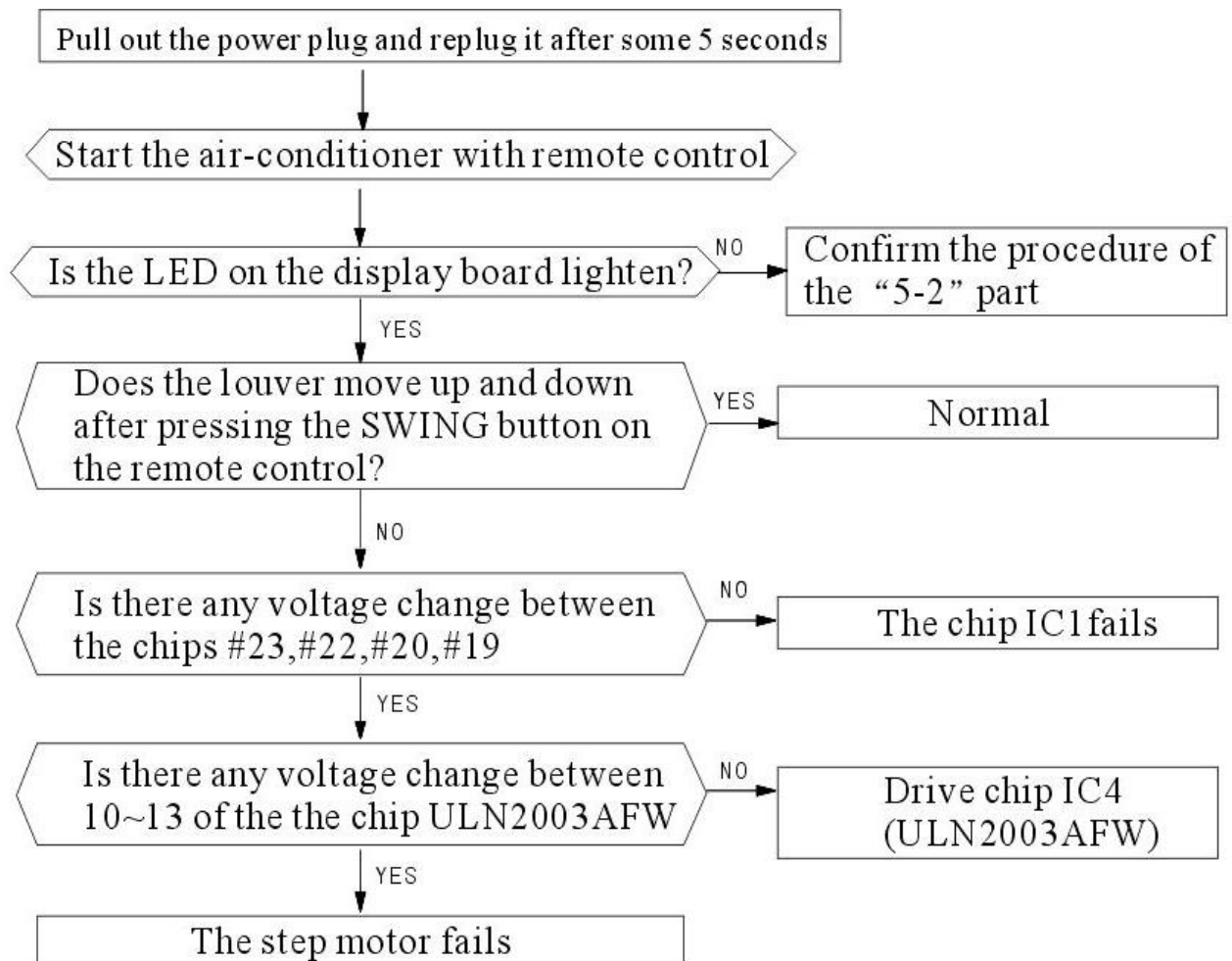

6. Heating Mode Can Work, But No Hot Air Blow

(1) Check if the set temperature is lower than the indoor temperature?

(2) Check if the indoor PCB is connected to the terminal correctly?

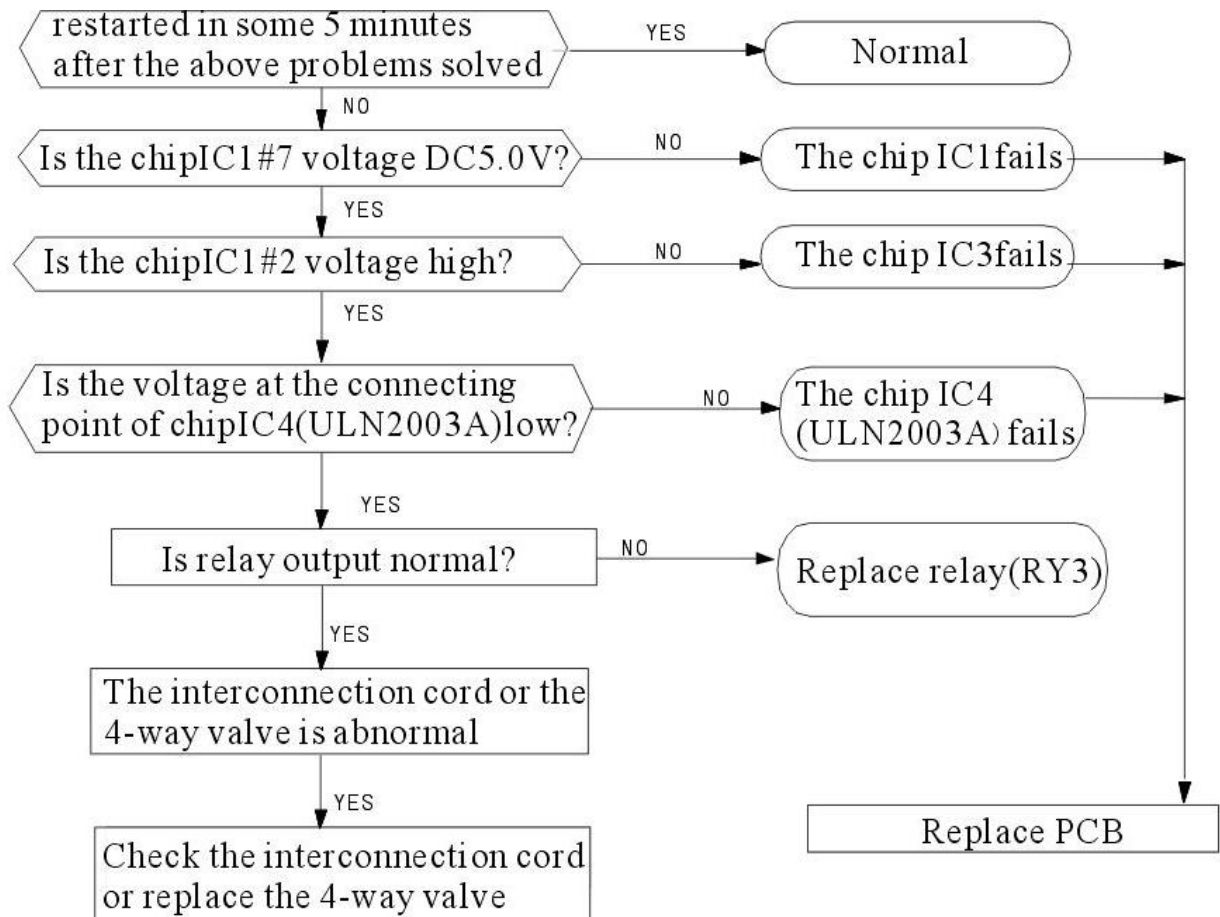

7. Remote Control Can Not Work

Trouble shooting rocedure

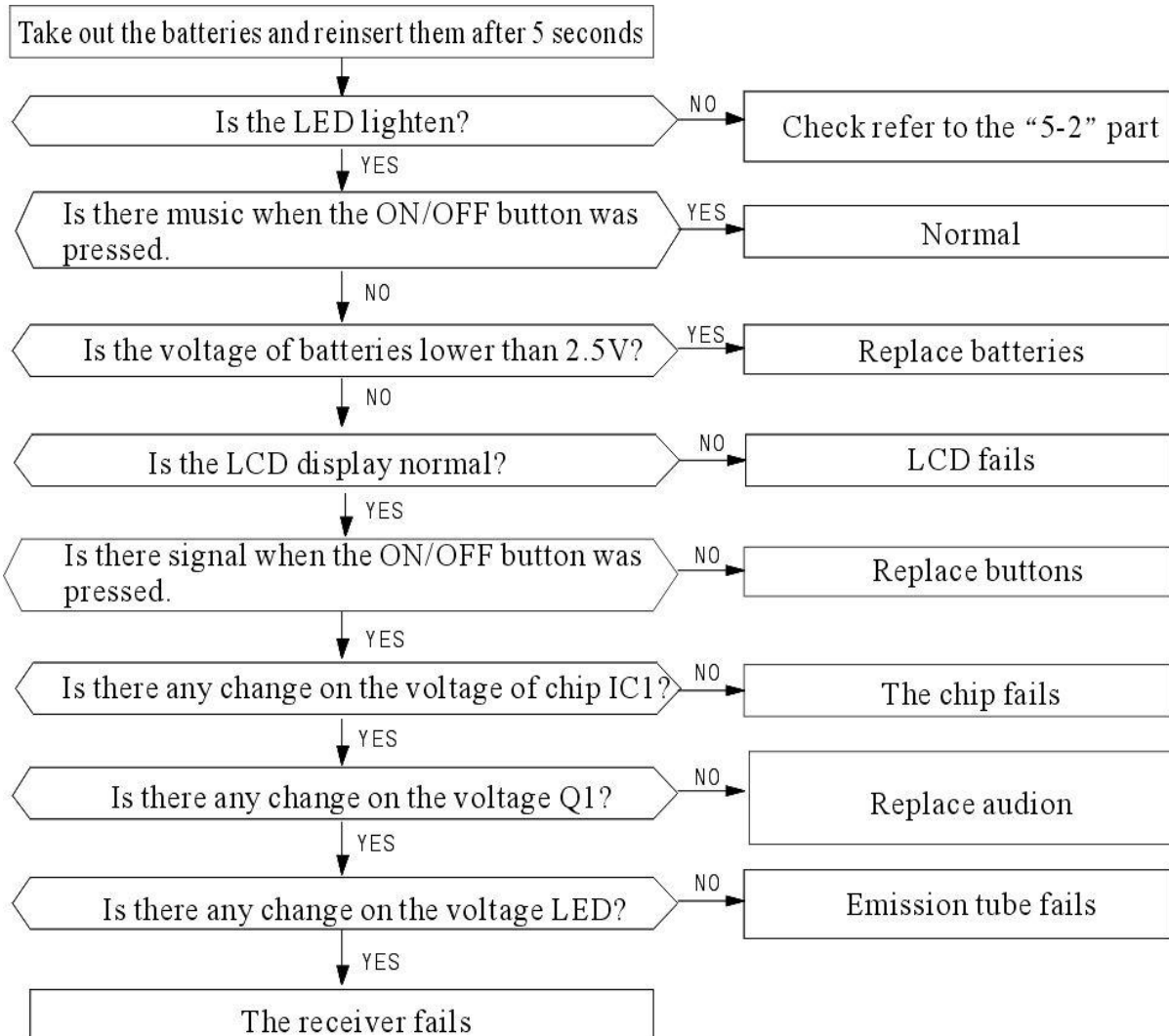

8. The Failure Analysis of the Main Parts

Part	Analysis																										
Heat exchanger	Measure resistance																										
	Normal	<table border="1"> <thead> <tr> <th>Environment temperature</th> <th>15℃</th> <th>20℃</th> <th>25℃</th> <th>30℃</th> <th>35℃</th> <th>40℃</th> </tr> </thead> <tbody> <tr> <td>Resistance of transformer(KΩ)</td> <td>7.45</td> <td>6.08</td> <td>5</td> <td>4.13</td> <td>3.43</td> <td>2.86</td> </tr> </tbody> </table>	Environment temperature	15℃	20℃	25℃	30℃	35℃	40℃	Resistance of transformer(KΩ)	7.45	6.08	5	4.13	3.43	2.86											
		Environment temperature	15℃	20℃	25℃	30℃	35℃	40℃																			
Resistance of transformer(KΩ)	7.45	6.08	5	4.13	3.43	2.86																					
Abnormal	∞ : Turn-off ; 0 Ω : Short-cut																										
The indoor fan motor	Detecting the resistance between each connecting terminal																										
	Normal	Environment temperature (10℃ ~30℃) <table border="1"> <thead> <tr> <th colspan="2">Between</th> <th>1</th> <th>2</th> <th>3</th> </tr> </thead> <tbody> <tr> <td>Blue、yellow</td> <td>Main</td> <td>410 Ω ±10%</td> <td>350 Ω ±10%</td> <td>370 Ω ±10%</td> </tr> <tr> <td>Blue、red</td> <td>Auxiliary</td> <td>325 Ω ±10%</td> <td>270 Ω ±10%</td> <td>300 Ω ±10%</td> </tr> <tr> <td colspan="2">Input</td> <td colspan="3">YYK13-4: 13W YYK19-4: 19W</td> </tr> </tbody> </table>	Between		1	2	3	Blue、yellow	Main	410 Ω ±10%	350 Ω ±10%	370 Ω ±10%	Blue、red	Auxiliary	325 Ω ±10%	270 Ω ±10%	300 Ω ±10%	Input		YYK13-4: 13W YYK19-4: 19W							
		Between		1	2	3																					
		Blue、yellow	Main	410 Ω ±10%	350 Ω ±10%	370 Ω ±10%																					
		Blue、red	Auxiliary	325 Ω ±10%	270 Ω ±10%	300 Ω ±10%																					
Input		YYK13-4: 13W YYK19-4: 19W																									
Abnormal	∞ : Turn-off ; 0 Ω : Short-cut																										
Detecting the voltage between the signal wire of fan motor and ground																											
Normal	<table border="1"> <thead> <tr> <th colspan="2">Between</th> <th>Voltage</th> </tr> </thead> <tbody> <tr> <td>Gray、Orange</td> <td></td> <td>0.5V~4.5V</td> </tr> <tr> <td>Yellow、Orange</td> <td></td> <td>5V</td> </tr> </tbody> </table>	Between		Voltage	Gray、Orange		0.5V~4.5V	Yellow、Orange		5V																	
Between		Voltage																									
Gray、Orange		0.5V~4.5V																									
Yellow、Orange		5V																									
Abnormal	voltage<0, voltage>5 is abnormal																										
Step motor	Normal	Environment temperature (10℃ ~30℃) <table border="1"> <thead> <tr> <th colspan="2">Between</th> <th>1</th> <th>2</th> <th>-</th> </tr> </thead> <tbody> <tr> <td colspan="2"></td> <td>24BYJ48</td> <td>35BYJ412B</td> <td>-</td> </tr> <tr> <td>Blue、yellow</td> <td>-</td> <td>Above 300 Ω</td> <td>Around 120 Ω</td> <td>-</td> </tr> <tr> <td>-</td> <td>-</td> <td>-</td> <td>-</td> <td>-</td> </tr> <tr> <td colspan="2">Input</td> <td>1.5W</td> <td>-</td> <td>-</td> </tr> </tbody> </table>	Between		1	2	-			24BYJ48	35BYJ412B	-	Blue、yellow	-	Above 300 Ω	Around 120 Ω	-	-	-	-	-	-	Input		1.5W	-	-
		Between		1	2	-																					
				24BYJ48	35BYJ412B	-																					
Blue、yellow		-	Above 300 Ω	Around 120 Ω	-																						
-	-	-	-	-																							
Input		1.5W	-	-																							
Abnormal	∞ : Turn-off ; 0 Ω : Short-cut																										
The outdoor fan motor	Detecting the resistance between the red wire and every connecting end																										
	Normal	When the temperature is 20℃ ~30℃ ,around 300 Ω and 120 Ω																									
	Abnormal	∞ : Turn-off ; 0 Ω : Short-cut																									

5.3 Руководство для моделей SAS24/30. Алгоритм. Проблемы и их устранение.

1. The Foremost Inspecting Items

(1)The input voltage must be within +10% tolerance of the rated Voltage. If it is not the case, the air-conditioner will probably not work normally.

(2)Check the connecting cord between indoor unit and outdoor unit to see if it is properly connected. The connecting must be done according to the wiring diagram, please also notice that even different models may have the connecting cord of the same specification.

Please check if the marks at the connecting terminal and the marks on the cord can match, otherwise, the air-conditioner will not work normally.

(3)If the following phenomena are found, the problem is not from the air-conditioner itself.

NO.	Problems	Causes
1	The motor is heard operating but the air-conditioner dose not work when the indoor unit is powered on	Since the air-conditioner is powered on, it will come to working condition as long as you press the ON/OFF button of the remote control and the signal is well received.
2	The compressor stops running but the indoor fan motor keeps working when it is at cooling mode with the indoor temperature higher than set temperature.	If you turn off the air-conditioner and restart it immediatly, it will return to normal in 3 minutes, after that, the air-conditioner will automatically adjust the indoor fan speed to what you set.
3	The compressor works discontinuously at dehumidifying mode.	The air-conditioner will automatically control the working of the compressor according to the inside temperature
4	The air-conditioner does not work while the LED display is on.	The TIMER is set with the air-conditioner; it will be in hold on condition. If the TIMER setting is cancelled, the air-conditioner will return to normal working condition.
5	The compressor works discontinuously at cooling and dehumidifying mode, and the indoor fan motor slows down.	The compressor stops internally or the fan motor slows down to prevent the indoor heat exchanger from being frozen.

2. No Power Display

(1) Items

- ① Check if the input voltage is correct?
- ② Check if the AC power supply connecting is correct?
- ③ Check if the output voltage of the manostat L7805(IC2) is correct?

(2) Trouble shooting procedure

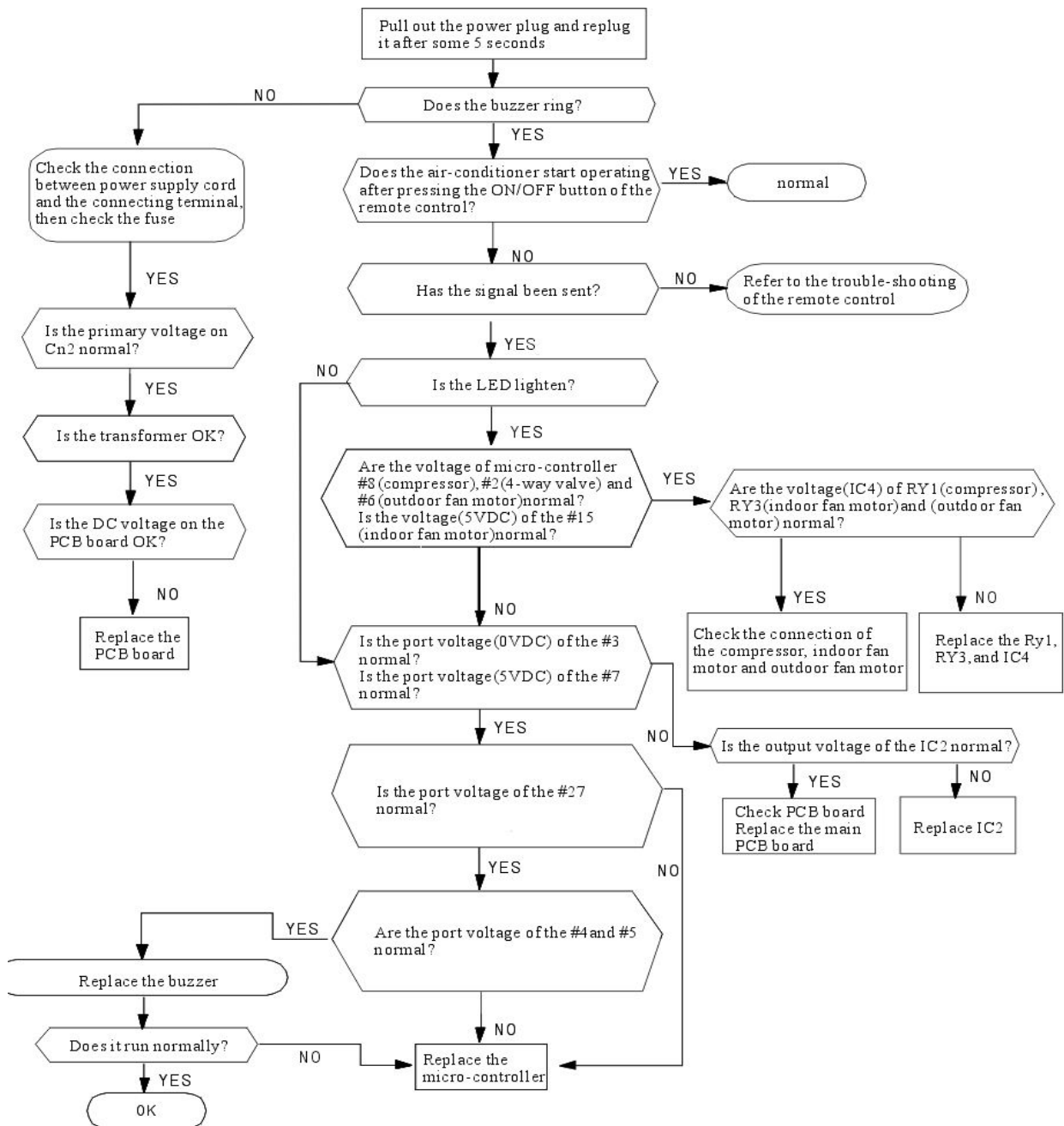

3. The Indoor Fan Motor Does Not Work

(1)Items

- ① Check if the indoor fan motor is connected correctly to the connector(CN8)?
- ② Check if the AC input voltage is correct?
- ③ Check if the IC of indoor fan motor is connected correctly to the connector(CN2)?
- ④ Check if the capacity of indoor fan motor is connected correctly to the connector(CN8)?

(2)Trouble shooting procedure

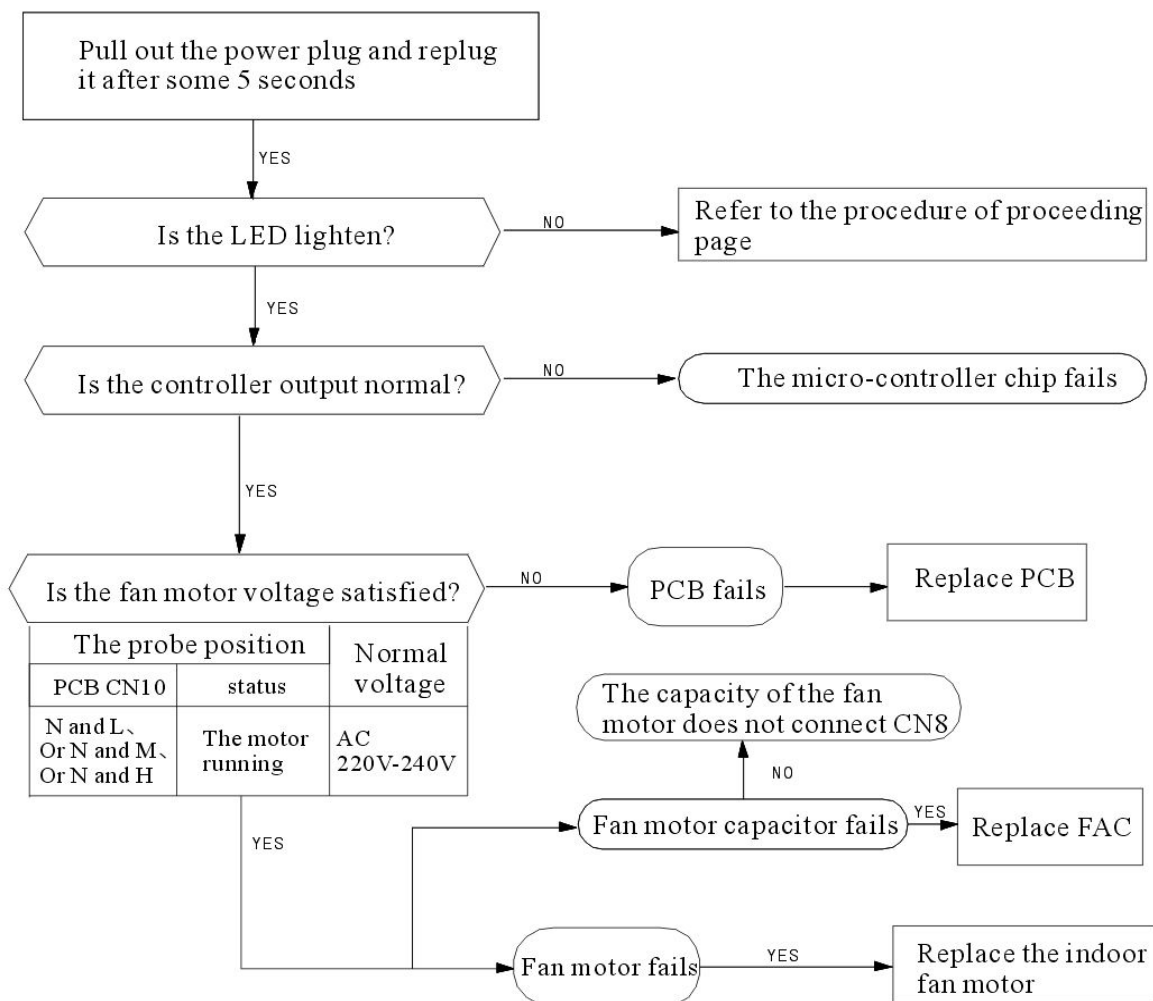

4. The Outdoor Unit Does Not Work

(1)Items

- ① Check if the input voltage is correct?
- ② Check if the wire connection of the outdoor connecting terminal is correct?

(2)Trouble shooting procedure

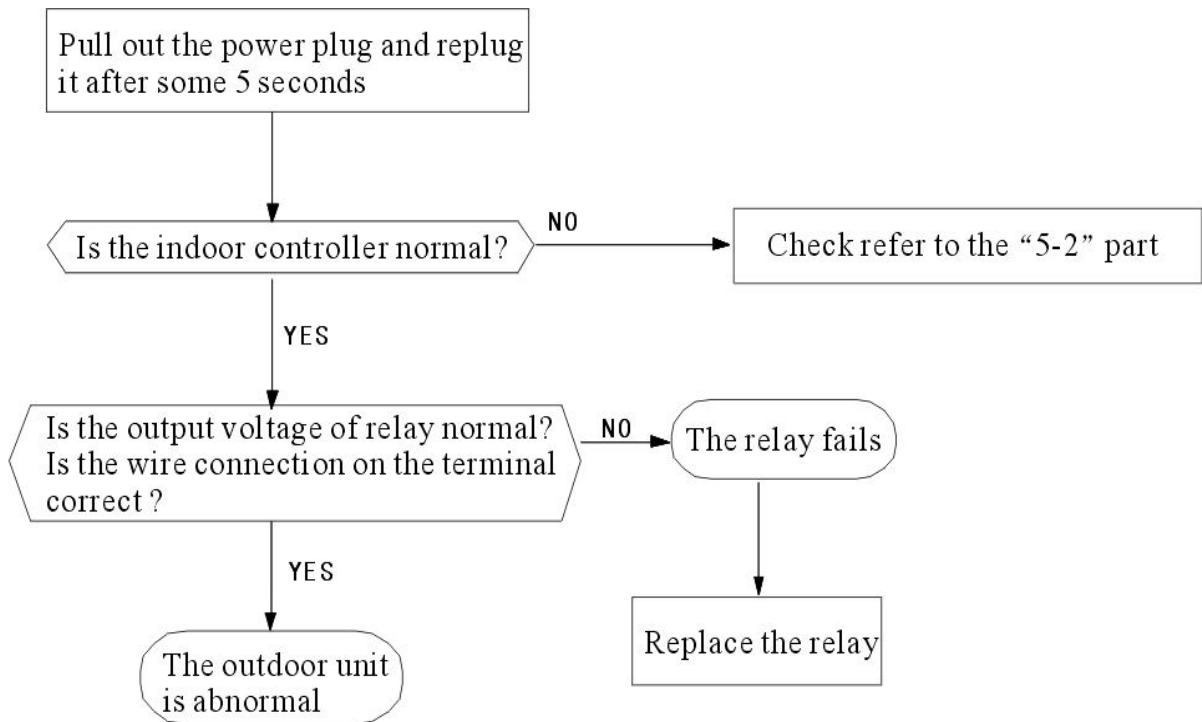

5. The Step Motor Does Not Work

(1)Items

①Check if the input voltage is correct?

②Check if the step motor controlling the up-down movement firmly connected to Cn2?

(2)Trouble shooting procedure

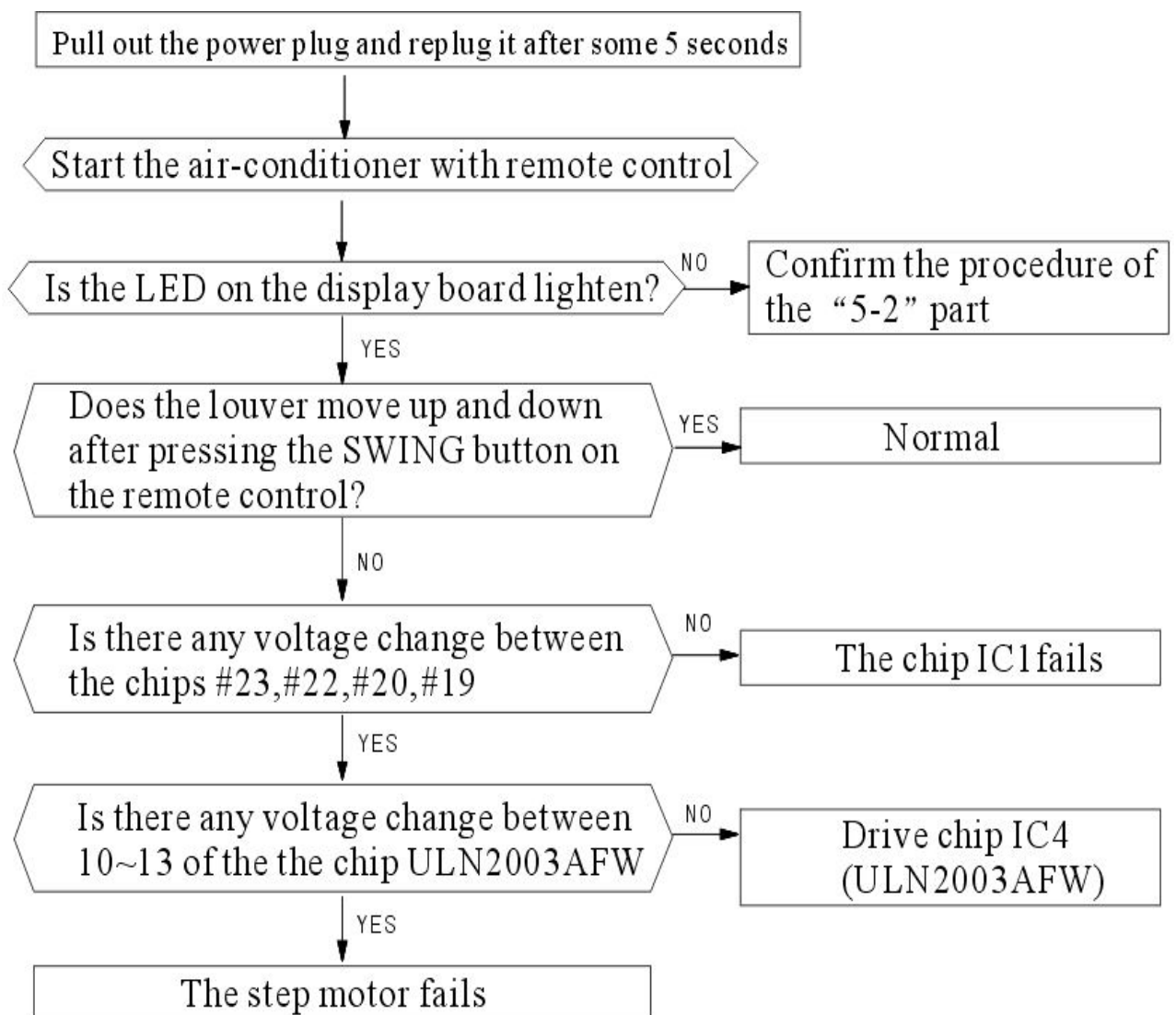

6. Heating Mode Can Work, But No Hot Air Blow

(1) Check if the set temperature is lower than the indoor temperature?

(2) Check if the indoor PCB is connected to the terminal correctly?

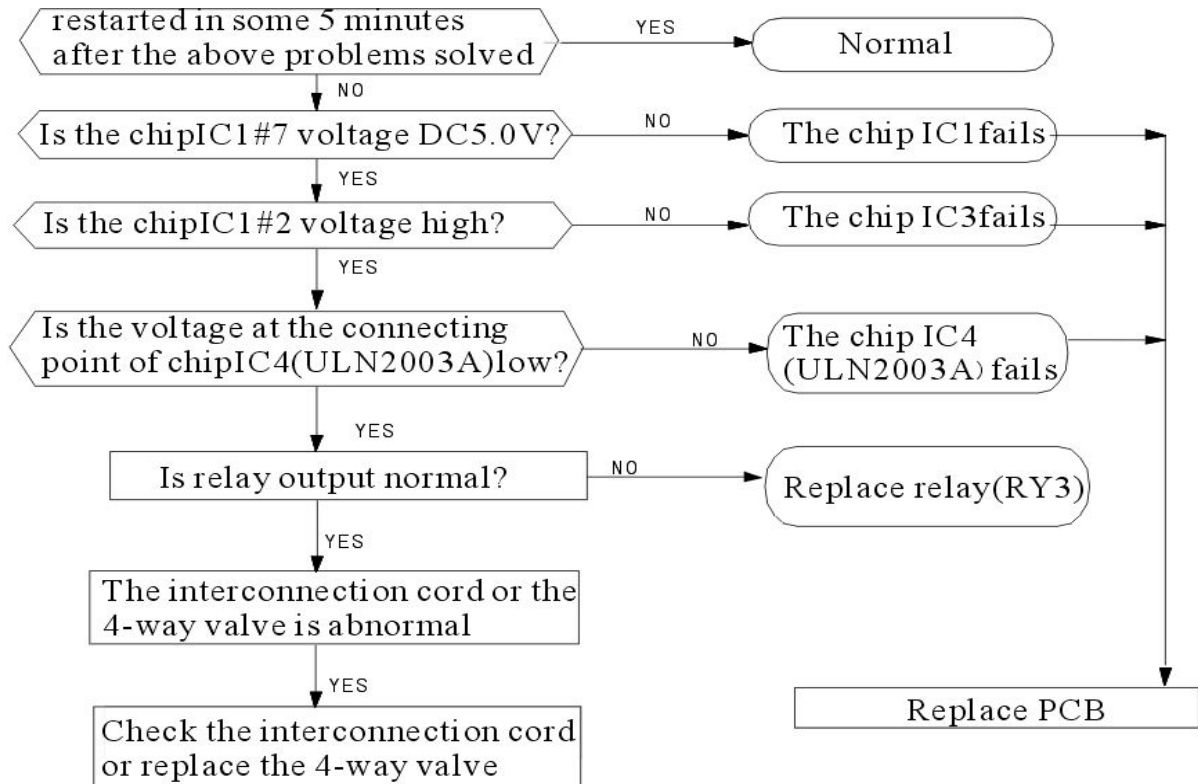

7. Remote Control Can Not Work

Trouble shooting procedure

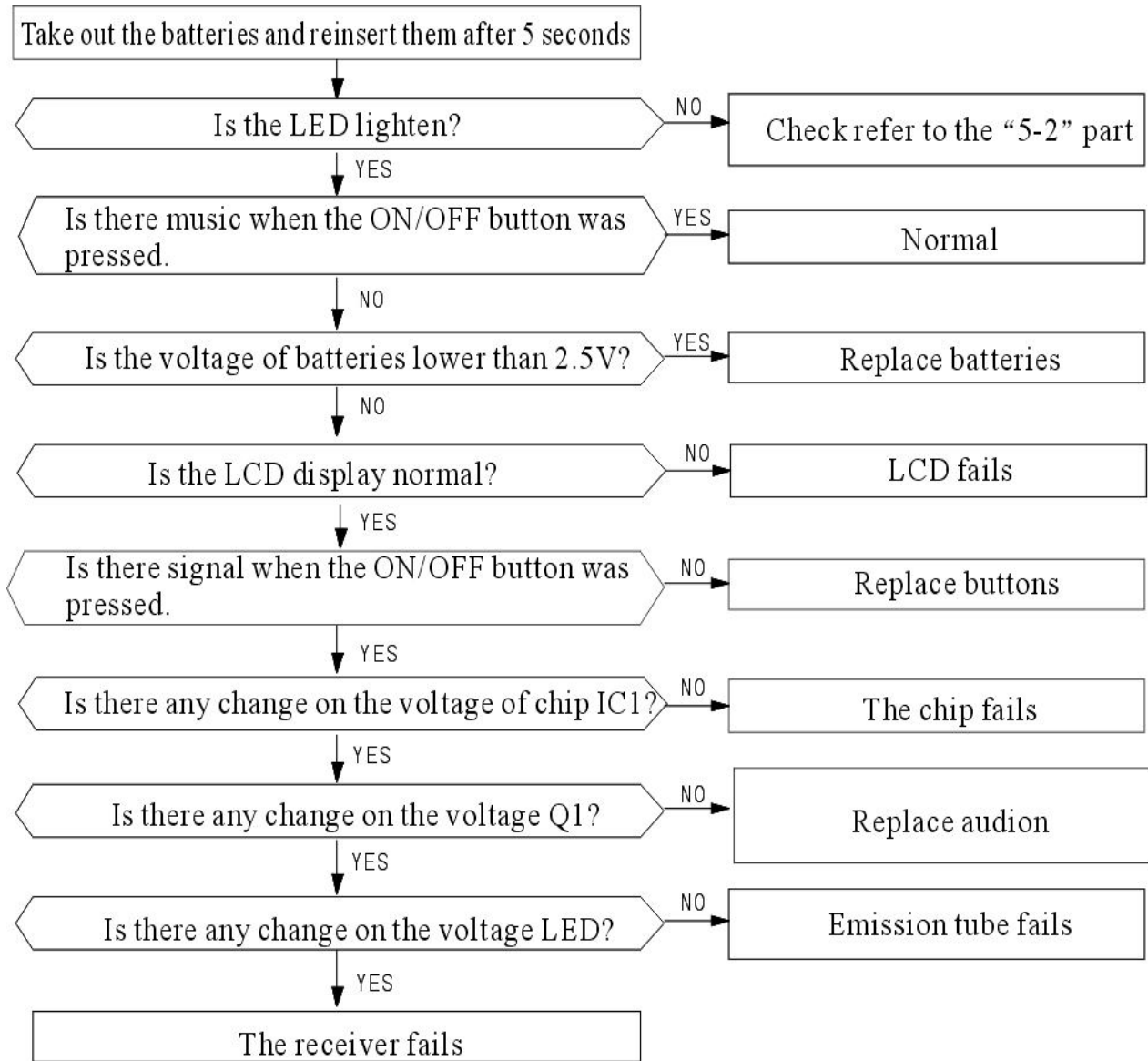

8. The Failure Analysis of the Main Parts

Part	Analysis							
Transformer Heat exchanger	Measure resistance							
	Normal	Environment temperature	15°C	20°C	25°C	30°C	35°C	40°C
		Resistance of transformer(KΩ)	7.45	6.08	5	4.13	3.43	2.86
Abnormal	∞ : Turn-off ; 0Ω : Short-cut							
Step motor	Normal	Environment temperature (10°C ~30°C)						
		Between		1	2	-		
				24BYJ48	35BYJ412B	-		
		Blue, yellow	-	Above300Ω	Around120Ω	-		
		-	-	-	-	-		
Input	1.5W		-	-				
Abnormal	∞ : Turn-off ; 0Ω : Short-cut							
The outdoor fan motor	Detecting the resistance between the red wire and every connecting end							
	Normal	When the temperature is20°C ~30°C ,around 300Ω and 120Ω						
	Abnormal	∞ : Turn-off ; 0Ω : Short-cut						